

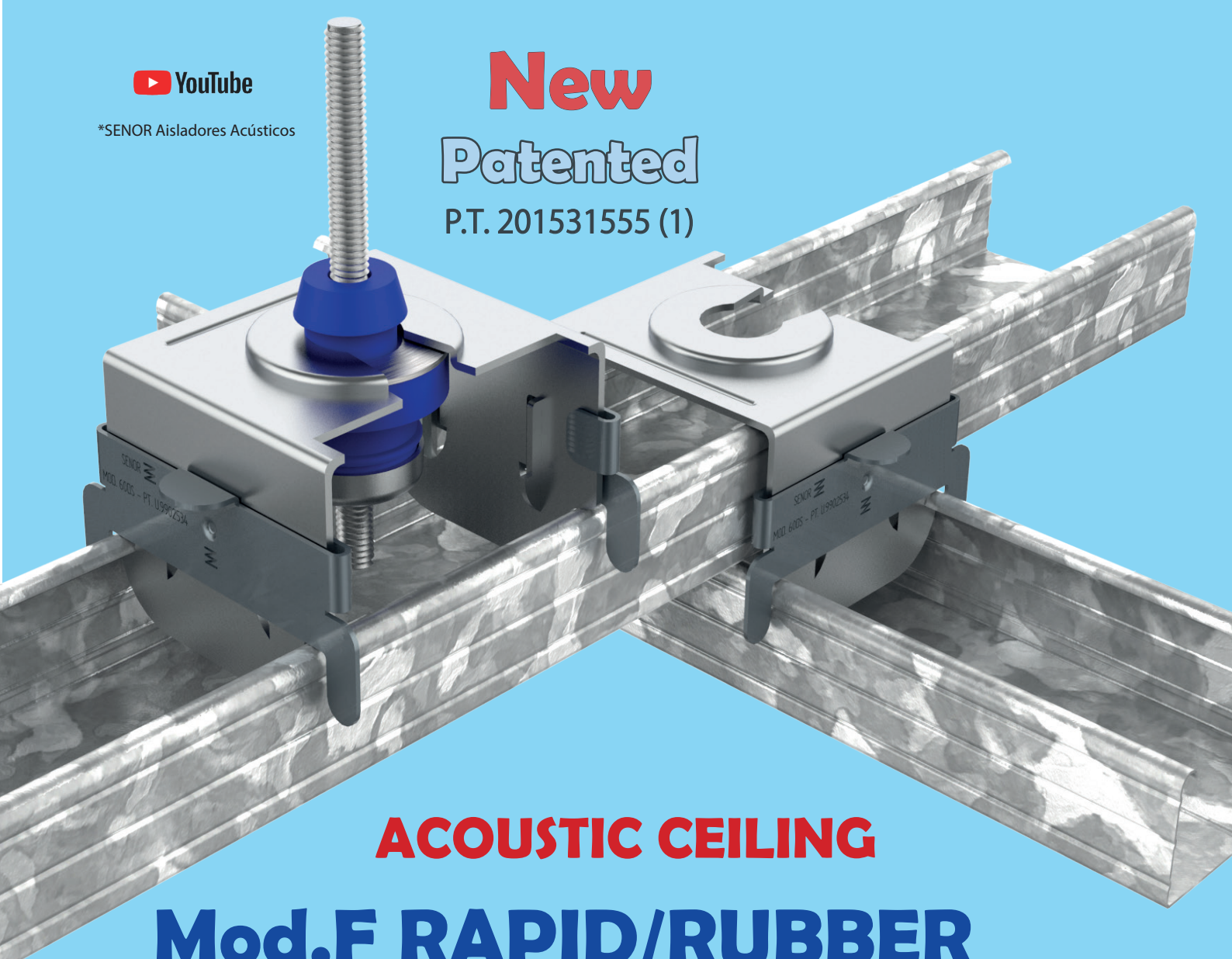

*SENOR Aisladores Acústicos

New
Patented
P.T. 201531555 (1)



ACOUSTIC CEILING
Mod.F RAPID/RUBBER

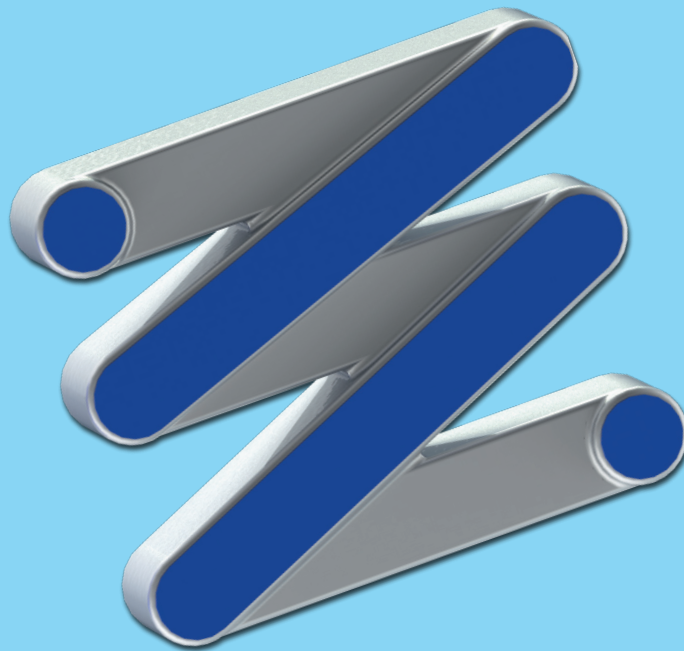

SENOR

MANUFACTURER OF ANTI-VIBRATION SYSTEMS

ACOUSTIC CEILING

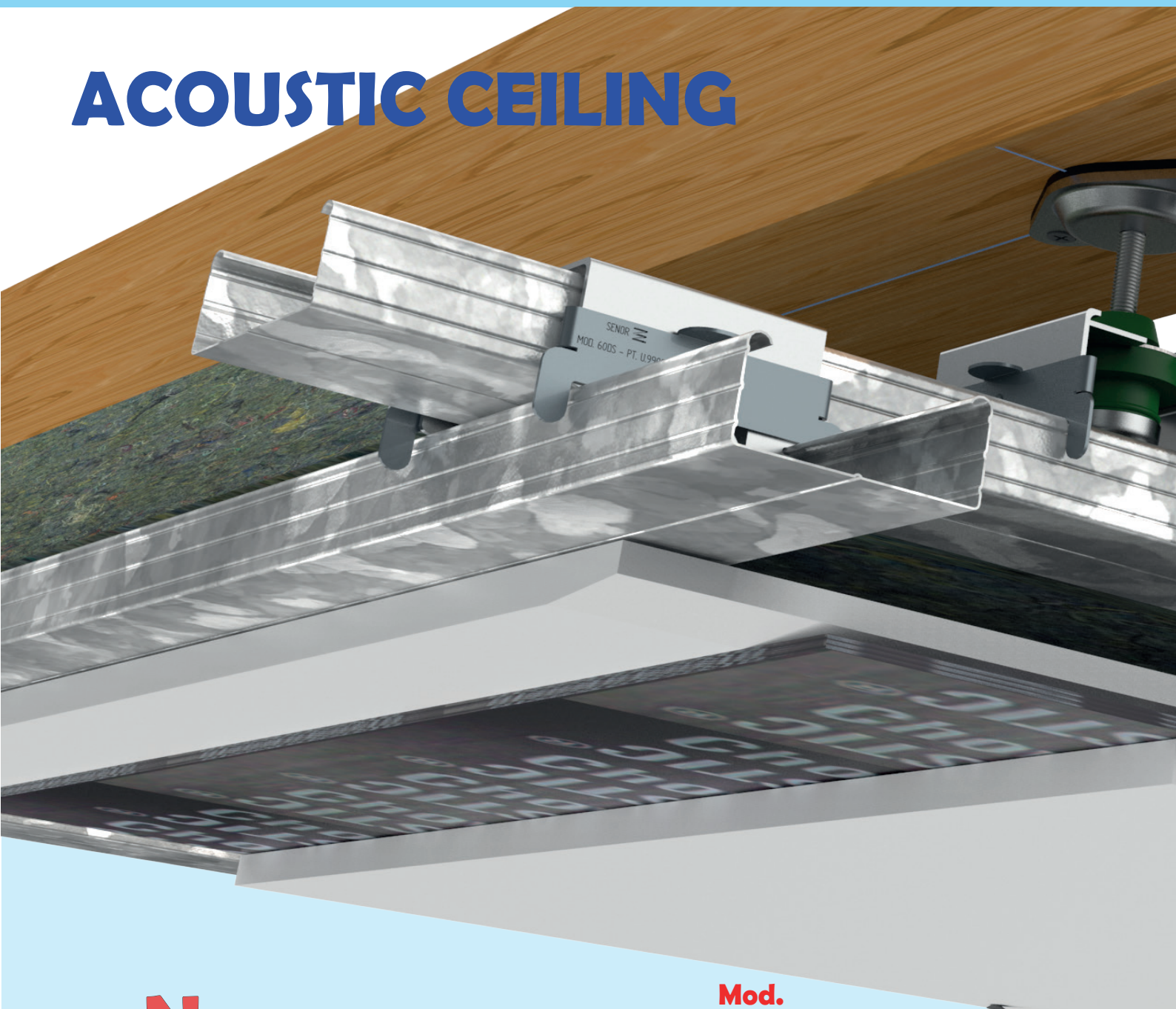

New

Patented

P.T. 201531555 (1)

Mod. F RAPID/RUBBER

From our very beginnings, we wanted to launch a shock absorber different from the rest by adding **Security**, **Innovation** and **Simplicity** to this product. After several years of research and development, we have reinvented this item from top to bottom. Now **SEÑOR** is able to offer a technological upgrade incorporating to the hybrid system an improved, renewed and original polymer "TC / GPN". Resulting in a new improved polymer that enhances its internal mechanical properties and provides a **>10%** increase in the field of acoustic isolation.

*SEÑOR Aisladores Acústicos

Introduction **F RAPID/RUBBER 60DS**.

A different and **RENOVATED** shock absorber. A very professional suspension. It is an acoustic support with constant **DEVELOPMENT** for the suspension of acoustic false ceilings, using galvanized steel profiles type **TC60**, **RIGI60**, **MAESTRA 60/27** or similar.

F RAPID/RUBBER 60DS is a 2-in-1 binding. It has the ability to become the safest and most cutting-edge channel intersection connector on the market with a simple gesture. Our engineers work every day for your safety. For this reason, the "**F RAPID**" incorporates the most advanced locking device of the moment.
(Only we manufacture it).

Main features.

They're fourth generation rubber shock absorbers, made with high performance and renewed raw materials, which provide important improvements in the vibro-mechanical field. It stands out for its simplicity. Its direct attachment to the 60 mm ceiling profiles make it unique. This type of acoustic isolator is designed to eradicate and attenuate the transmission of vibrations produced by equipment with rotating and repetitive shocks above **20Hz**.

ACOUSTIC CEILING.

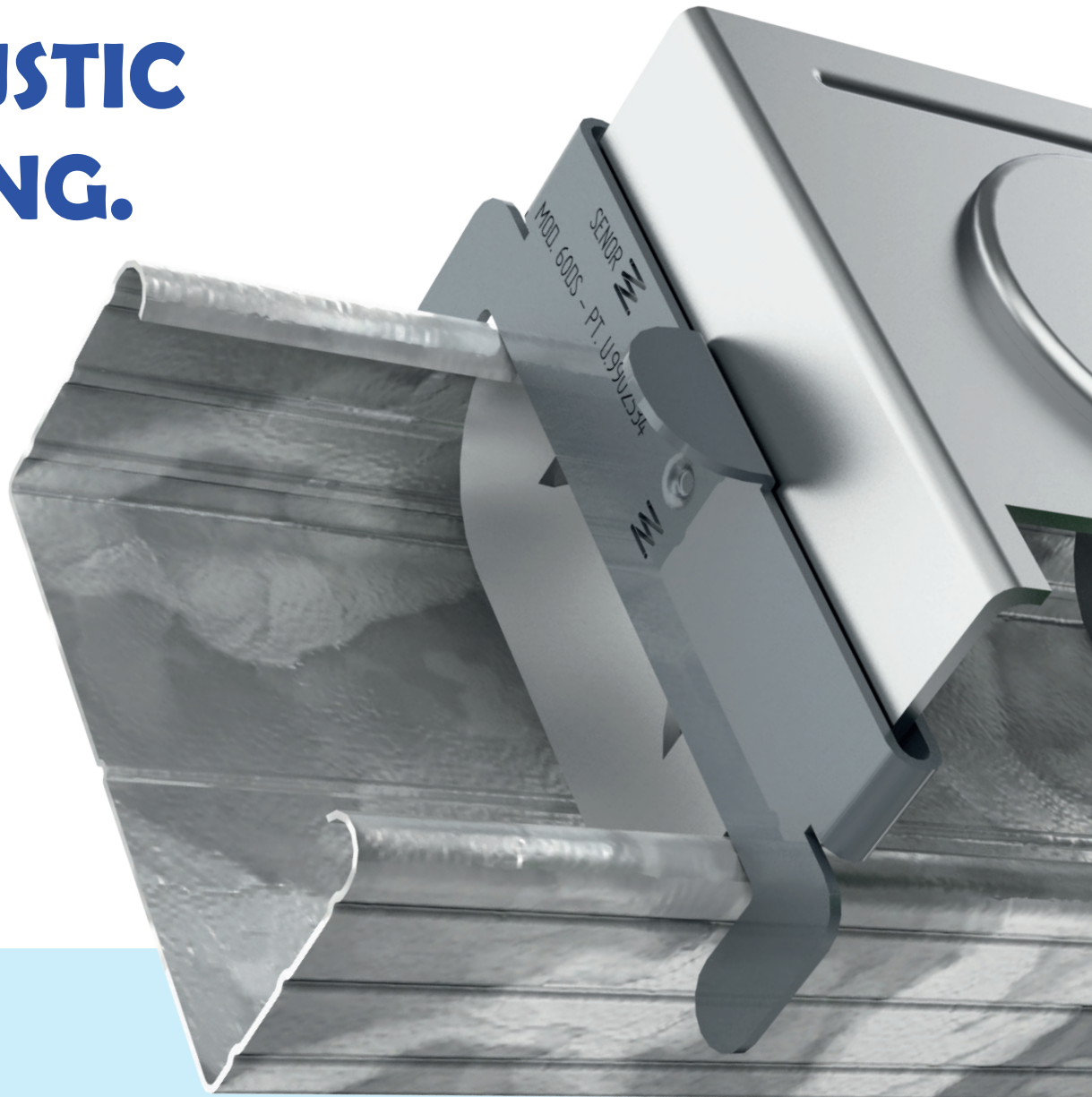

DYNAMIC load capacity.

For the design of acoustic ceilings, there is a very wide diversity of construction solutions, where the distribution of the load will depend on different variables, such as: **mass m^2** , **distance between the inter-axes of the ceiling profiles**, **arrangement of the shock absorbers on the framing**, etc... The **F RAPID/RUBBER** range has the advantage of combining two colors to differentiate the load per unit (kg): **GREEN** and **BLUE**. The **GREEN** colour will indicate the one with the lowest load capacity, (between **3Kg** up to **25kg** of maximum load). Whereas the **BLUE**, colour, the one with the highest load (between **20Kg** up to **45kg** maximum load). In this way we can choose the most effective shock absorber depending on the system.

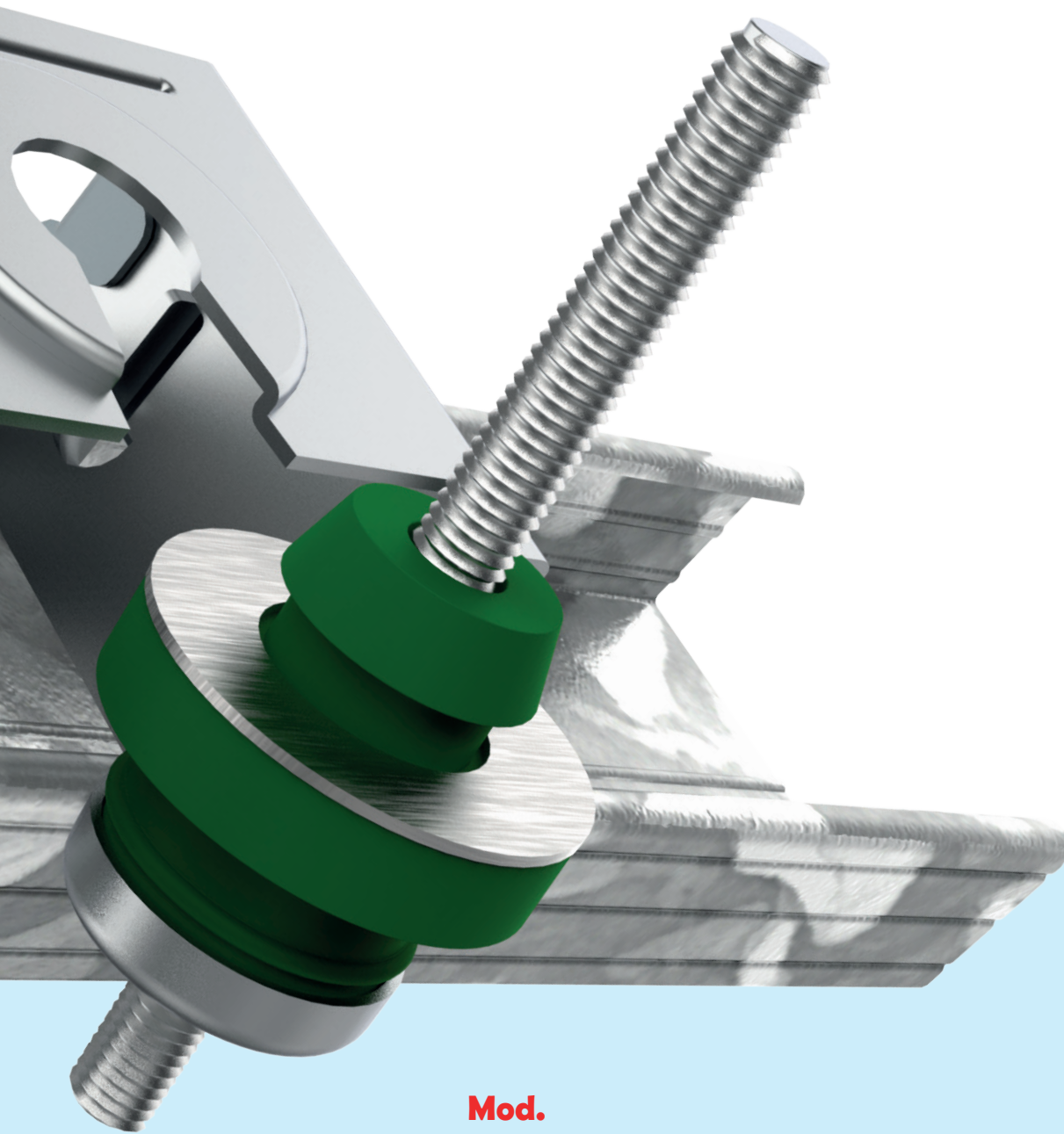

Mod.
F RAPID/RUBBER

New
Patented
P.T. 201531555 (1)

ACOUSTIC CEILING.

Ref.
F RAPID/RUBBER 60 V

Green Plus Rubber: "TC-4/GPN"

Loads between **3-25 Kg.**

Resonance frequency **7** up to **15Hz.**

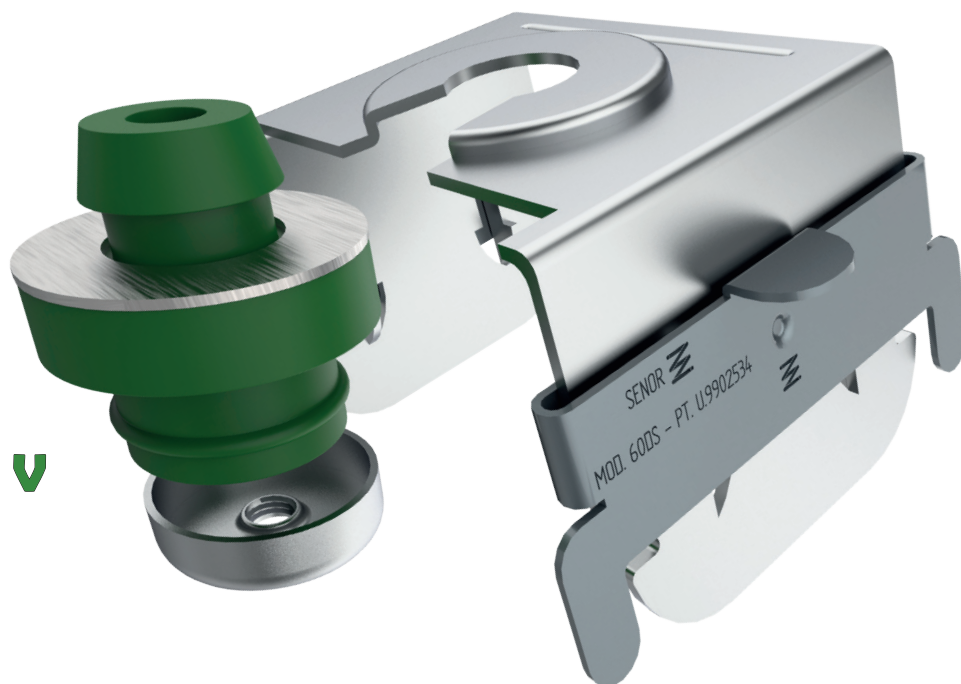

New
Patented
P.T. 201531555 (1)

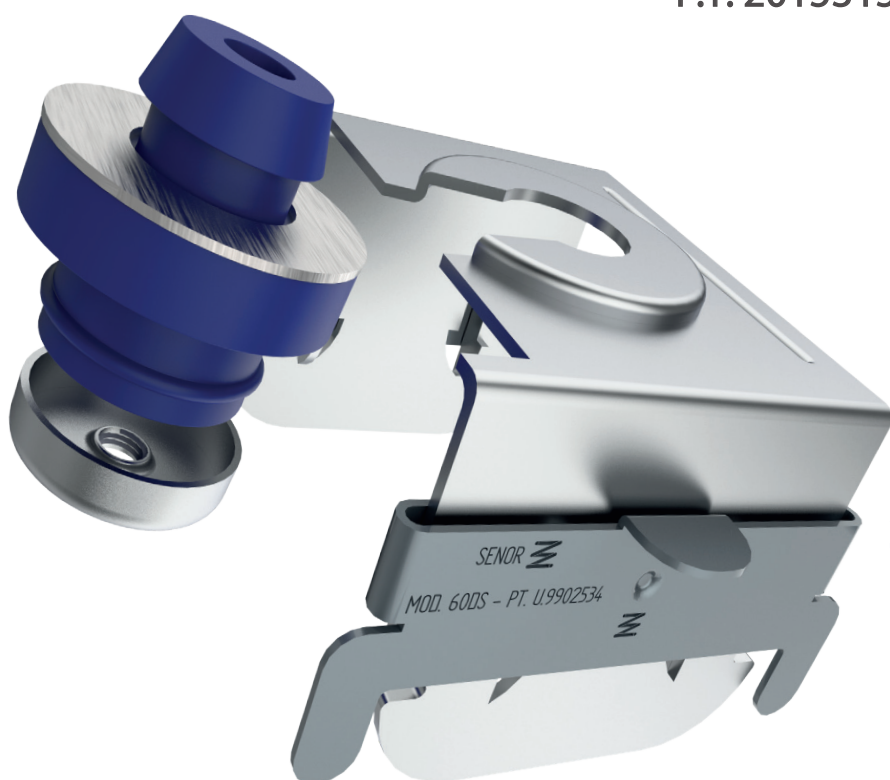
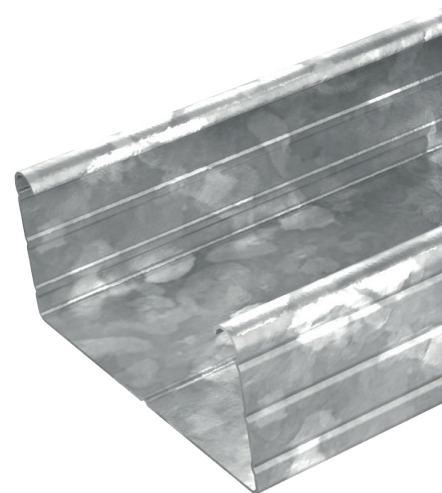

Ref.
F RAPID/RUBBER 60 A

Goma PLUS Azul: "TC-5/EXN"

Loads between **20-45 Kg.**

Resonance frequency **7** up to **15Hz.**

Mod.
F RAPID/RUBBER

LABORATORY test. UNE-EN ISO 10846-1:2009

Acoustics and vibrations. Laboratory measurement of the vibroacoustic transfer properties of elastic elements.

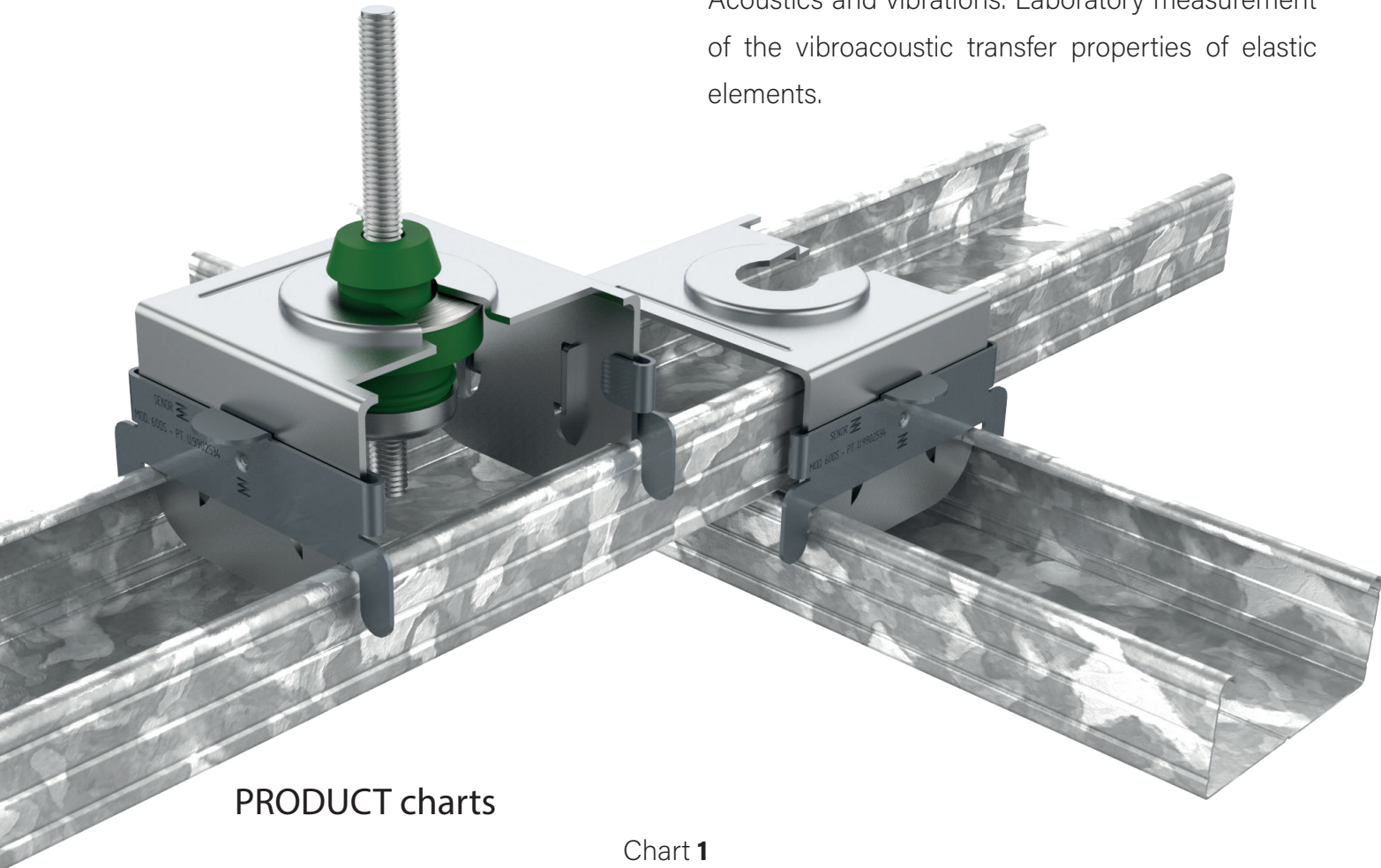

PRODUCT charts

Chart 1

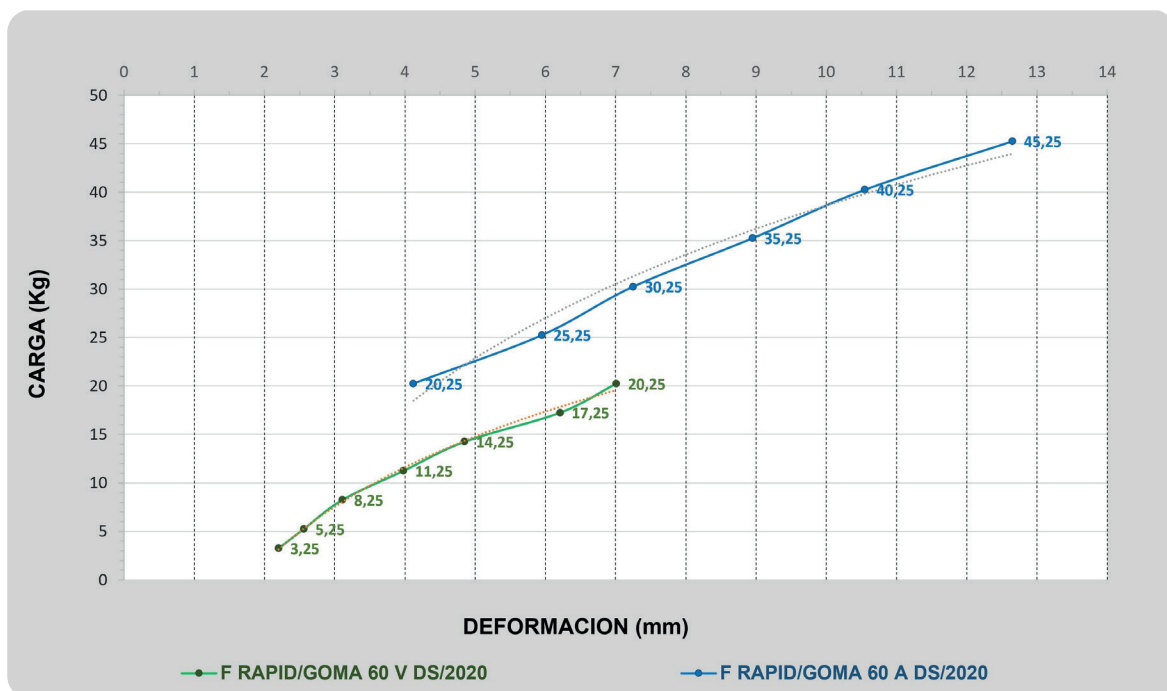

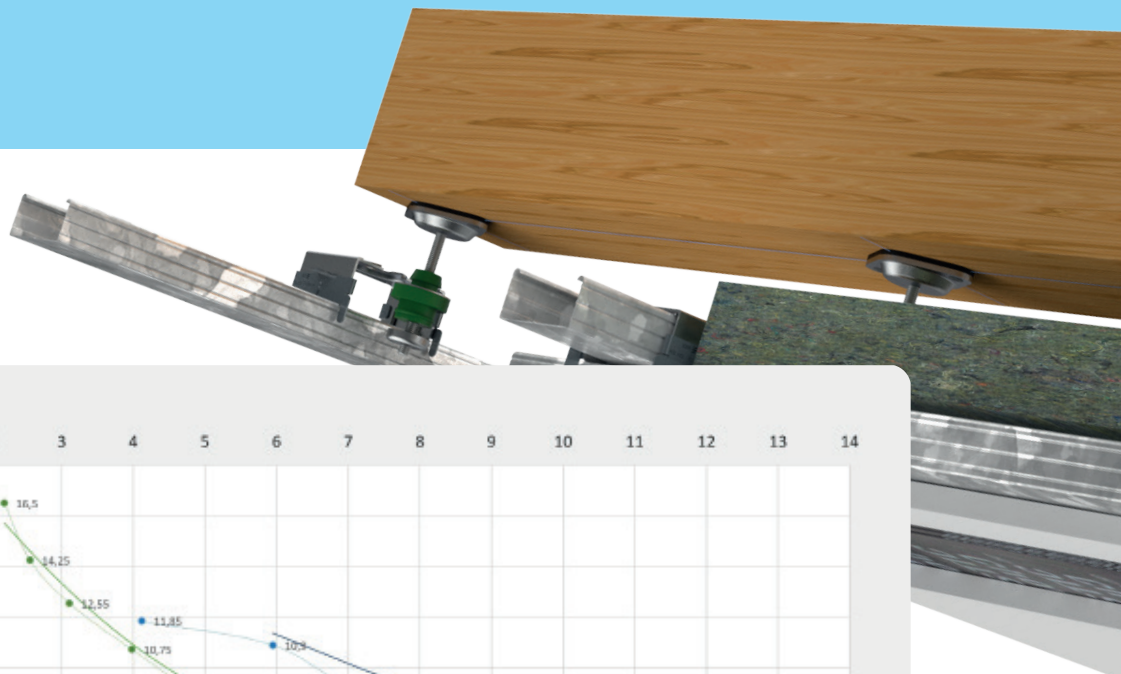

Chart 2

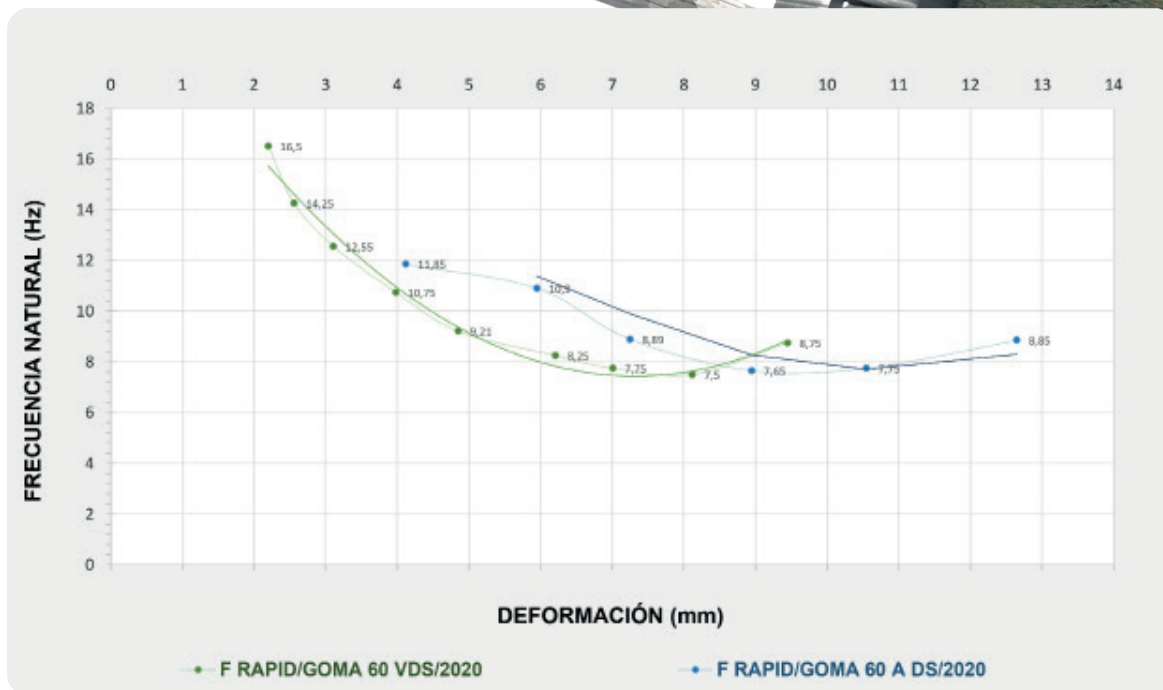
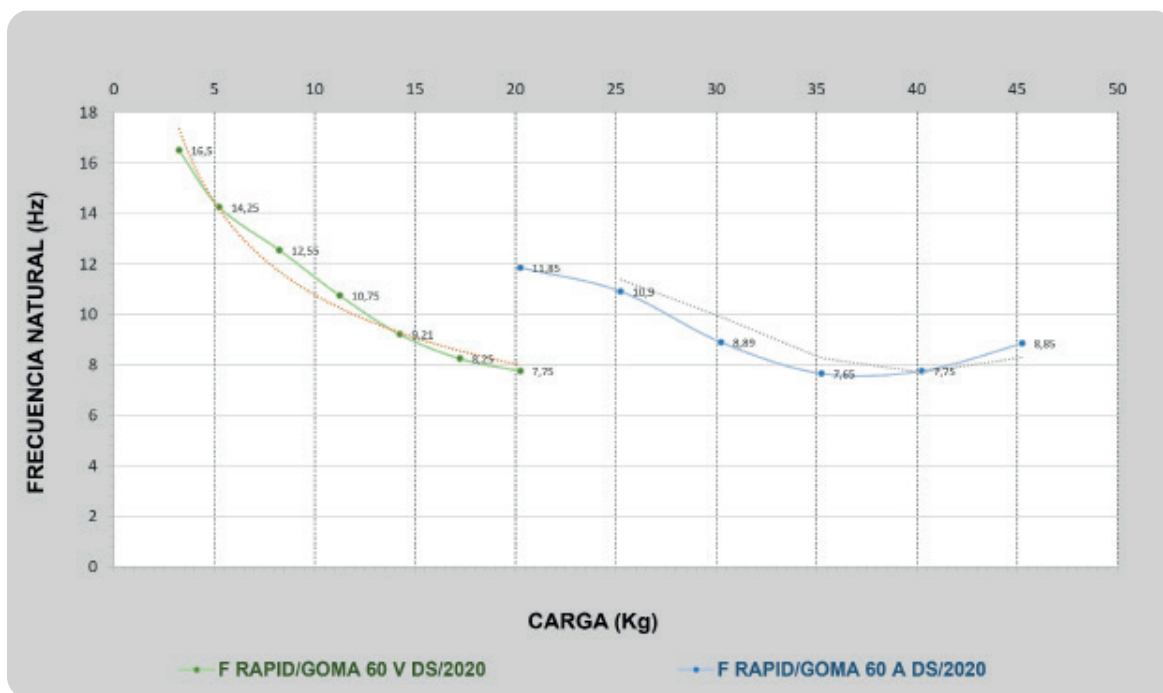

Chart 3



Ref.
F RAPID/RUBBER 60 V



New
Patented
P.T. 201531555 (1)

Ref.
F RAPID/RUBBER 60 A



Product measurements

Mod.
F RAPID/RUBBER

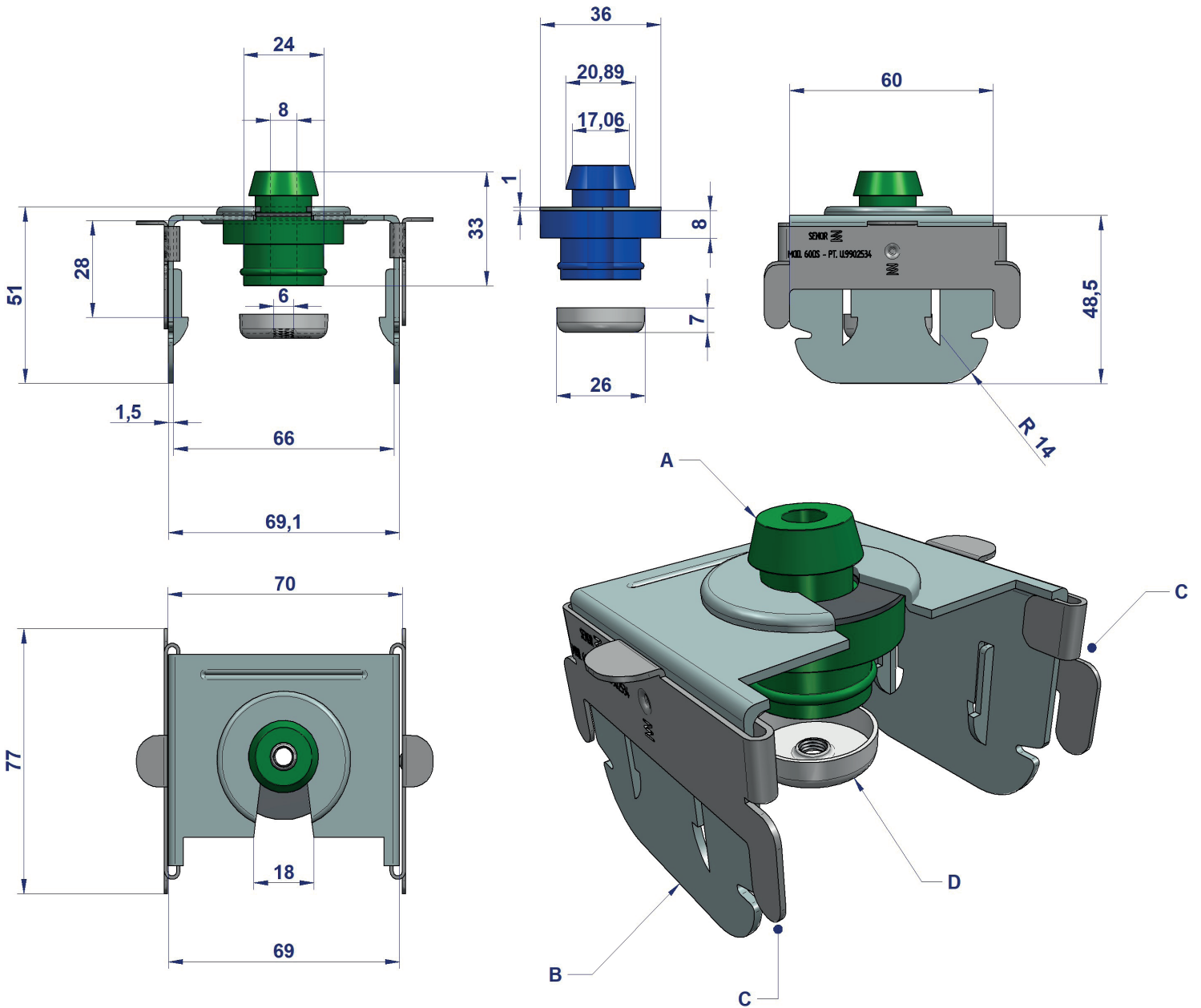

MAIN Components

(A) **Upper cap with protruding neck**, which prevents contact between the threaded rod and the metal components (B). It also provides a perfect seating to the bowl-shaped metallic piece (D) and optimal performance in the mid / high frequency range (HZ).

Mod.
F RAPID/RUBBER

New
Patented
P.T. 201531555 (1)



(B) Galvanized steel outer casing, made of high-performance galvanized steel **Dx54d + Z140** with an edge thickness of 1.5 millimeters. It provides rigidity to the system and facilitates quick insertion to the ceiling profile.

(C) Locking device (DS), Made of high performance galvanized steel **Dx54d + Z140**, with an edge thickness of 1 millimeter. **SAFETY**: It breaks above 300 Kg punctual.

(D) Bowl-shaped metallic piece, made of high performance galvanized steel **Dx54d + Z140** with an edge thickness of 1.5 millimeters. It provides the resistance to mechanical traction of the system. **BREAKING**: t breaks the thread turns of the threaded rod above 250 Kg punctual.

CERTIFICATE OF COMPLIANCE



SEÑOR certifies..

All our products in the construction range for the suspension of acoustic false continuous ceilings. **Mod.F RAPID/RUBBER 60 DS,** , have an optimal lifespan of 10 years; provided that the installation is carried out under normal environmental conditions and are not either exposed to chemical components that could degrade the product. The model F.RAPID/RUBBER 60 DS rigorously complies with UNE 100-153-88: anti-vibration mounts: selection criteria.



Warning Important information

SEÑOR"; reserves the right to make changes in specifications at any time without prior notice. It is a responsibility of the user to use the latest and updated version of the product data sheets. A copy of which will be available on request. This information and, in particular, relative recommendations to the application and final use of the product, are given in good faith, based on "SEÑOR" knowledge and experience of its products, provided that they are correctly installed in normal circumstances and within its useful life.

Project manager: David Muñoz "SEÑOR"

New

Patented
P.T. 201531555 (1)

DECLARACIÓN DE CONFORMIDAD

(DIRECTIVA 89/106/CEE SOBRE LOS PRODUCTOS DE CONSTRUCCIÓN)

EC DECLARATION OF CONFORMITY

(CONSTRUCTION PRODUCTS DIRECTIVE 89/106/CEE).

SUSPENSIONES ELÁSTICAS DEL NORTE, S.L. ([SEÑOR](#))

P.I. El Garrojal, Parcela 10, módulo 4 y 5 / Palma del Río (CÓRDOBA) España (SPAIN)

DECLARA BAJO SU RESPONSABILIDAD QUE LOS SIGUIENTES **COMPONENTES DE SUBSTRUCTURA DE TECHO SUSPENDIDO** UTILIZADO EN INTERIORES DE EDIFICIOS: DECLARES UNDER ITS RESPONSIBILITY THAT THE FOLLOWING SUSPENDED CEILING SUBSTRUCTURE COMPONENTS TO BE USED INSIDE BUILDINGS.

USED FOR INTERIOR APPLICATIONS:

MODELO/MODEL: [SE-F RAPID/GOMA 60 DS.](#)

REFERENCIAS/REFERENCES:

MÉTRICA/METRIC: 6 y 8.

PERFIL/PROFILE: 60 milímetros

SE-F RAPID/GOMA 60 V DS/M6

SE-F RAPID/GOMA 60 A DS/M6

SE-F RAPID/GOMA 60 V DS/M8

SE-F RAPID/GOMA 60 A DS/M8

CUMPLE LOS REQUISITOS DE LA NORMA

MEET THE REQUIREMENTS OF THE STANDARD

UNE-EN 13964:2006; UNE-EN 13964:2006/A1:2008

EN 13964:2006; EN 13964:2006/A1:2008

APLICACIONES:

APPLICATIONS:
CEILINGS

PARA USO EN LA INSTALACIÓN DE FALSOS TECHOS ACÚSTICOS.

TO BE USED IN THE INSTALLATION OF ACOUSTIC

FECHA DE EMISIÓN: 05/02/2020

ISSUED ON: 05/02/2020

RE: DCE 002-ver 1

GERENTE/MANAGING DIRECTOR

Ms Carmen López Iglesias